

Robust tow tractor with spring-loaded wheels for indoor and outdoor use

Comfortable operation

Automatic parking brake

Electronic "SpeedControl" provides smooth acceleration

High energy efficiency with maintenance-free AC technology

Weather protection cabins (optional)



EZS 570NA

Tow Tractor (15,400 lbs.)

The Jungheinrich® EZS 570NA is a versatile, economic tow tractor for towing loads up to 15,400 lbs. The ability to connect several trailers together helps to provide flexibility and increased efficiency in most material handling operations.

The coupler is visible from the operator seat position and is easily accessible. The semi-automatic remote release (optional) allows the connecting and disconnecting of trailers without the operator having to leave the vehicle, helping to save both time and money. The EZS 570NA is also available with many different hitches to allow it to fit virtually every trailer type.

The 48 Volt drive motor using AC technology can provide additional performance. The advantages: powerful acceleration and high top speed with significant energy savings, in addition to extended operating times and reduced maintenance through omission of carbon brushes. This is due to the effective set-up between both drive motor and the electronic controller, as well as regenerative braking.

The EZS 570NA is designed with optimum ergonomic features. The position of the operator seat provides ample leg room while still allowing the operator to be in

close proximity to the load, and the low step is ideal for effortless entry and exit from the tow tractor.

The short turning radius of the EZS 570NA helps the operator move in tight spaces with minimal effort, while the spring-loaded wheels offer both comfort and stability during travel. The tow tractor also features an electric parking brake, which automatically engages when the truck is not moving – to reduce the chance of rollbacks when operating on sloped surfaces.

EZS 570NA

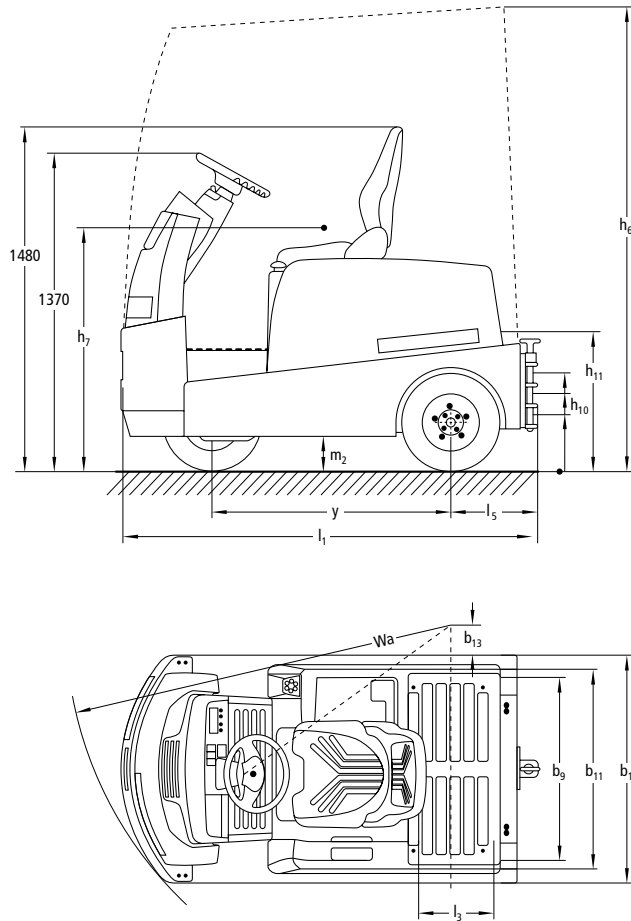

Performance Diagram EZS 570NA

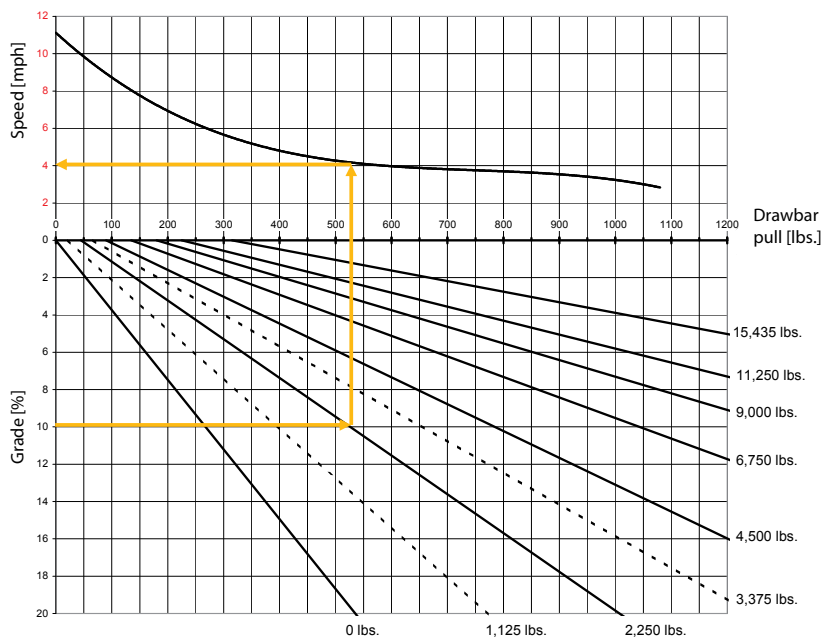

Example:

When the EZS 570NA pulls a 3,375 lb. load up a 3% grade, it requires 250 lbs. of drawbar pull and achieves a maximum speed of 6 mph.

Notes:

- 1) Continuous operation over 240 lbs. (force) is not permitted.
- 2) The use of braked trailers is strongly recommended for operation on upward / downward grades over 4%.

Characteristics	1.1	Manufacturer				Jungheinrich	
	1.2	Manufacturer's type designation				EZS 570NA	
	1.3	Drive				electric	
	1.4	Type of operation				seated	
Weights	1.5	Load capacity / rated load	Q	lb	kg	15,400	7,000
	1.9	Wheelbase	y	in	mm	41.0	1,035
Weights	2.1	Service weight including minimum weight battery		lb	kg	2,635	1,195
	2.3	Axle loading, unloaded front / rear with minimum weight battery		lb	kg	1,230 / 1,405	560 / 635
Wheels, Chassis	3.1	Tires				solid pneumatic	
	3.2	Tire size, drive				15.8x4-8	
	3.3	Tire size, rear				15.8x4-8	
	3.5	Wheels, number drive / rear				1 / 2	
Dimensions	3.7	Tread width, rear	b ₁₁	in	mm	34.0	860
	4.7	Height of overhead guard (cabin)	h ₆	in	mm	83.5	2,120
	4.8	Seat height	h ₇	in	mm	40.5	1,030
	4.12	Coupling height		in	mm	9.5 / 16.5 ²⁾	240 / 420 ²⁾
	4.19	Overall length	l ₁	in	mm	71.5	1,820
	4.21	Overall width	b ₁	in	mm	39.5	996
	4.32	Ground clearance, center of wheelbase	m ₂	in	mm	5.4	138
	4.35	Turning radius	Wa	in	mm	65.0	1,650
Performance	4.36	Internal turning radius	b ₁₃	in	mm	4.1	105
	5.1	Travel speed, loaded / unloaded		mph	km/h	5.3 / 11.2	8.5 / 18
	5.5	Drawbar pull		lb force	N	315	1,400
	5.6	Maximum drawbar pull		lb-force	N	1,230	5,500
Performance	5.7	Gradeability		%		- ¹⁾	- ¹⁾
	5.10	Service brake				hydraulic / mechanical	
Electrical	6.1	Drive motor rating S ₂ 60 minute		HP	kW	5.7	4.3
	6.4	Battery voltage, nominal capacity				V/Ah	
	6.5	Battery weight (minimum / maximum)		lb	kg	1,210 / 1,320	550 / 600
Other	8.1	Type of drive control				impulse / AC	
	8.4	Sound level at driver's ear				dB (A)	
1) see diagram. 2) other coupling heights available.							

This specification sheet only provides technical values for the standard truck. Non-standard tires, different masts, additional equipment, etc., could produce other values. Rights reserved for technical changes and improvements.

The Jungheinrich Advantage

Efficient AC technology

Jungheinrich motors with AC technology provide increased efficiency with reduced operating costs while also offering:

- Higher efficiency with excellent energy consumption.
- Powerful acceleration.
- High top speed, even when loaded.
- Stepless travel direction changes.
- No carbon brushes – the drive motor is maintenance free.

Comfortable, productive operation

The electronic SpeedControl management system and automatic electric braking system work together to facilitate comfortable and secure operation of the vehicle. Adjustment opportunities are available to suit many applications:

- The travel speed set by the position of the accelerator is automatically maintained regardless of gradient.
- Three programmable performance modes to suit various applications.
- Regenerative braking returns energy to the battery during deceleration.
- Secure starting and stopping, even on slopes, with the electric parking brake, which automatically engages when stationary and automatically releases when starting.
- Crawl speed button for traveling at reduced speed (speed adjustable).



Ergonomic low step for effortless entry and exit to and from the vehicle

Optimum ergonomics

- Low step for effortless entry and exit from the vehicle.
- Close proximity of operator position to trailer and load.
- Highly visible and accessible coupling.
- Multiple storage areas for the operator.

Rugged construction for demanding applications

- Chassis made of high-quality 0.31 inch thick plate steel.
- Extra high bumper on the front end.
- Robust, high intensity, LED (light emitting diode) rear lights and indicators.

Long operating times

- Energy efficient AC technology and high battery capacity, together with regenerative braking, provide longer operating times.

Well informed at any time

Easy-to-read display and instruments always allow a complete overview for the operator:

- Battery discharge indicator, operation hours, travel speed and fault diagnostics.
- Adjustable travel parameters.



Clear layout of controls provides easy operation of the tow tractor

Available options

The EZS 570NA may be customized to fit your individual application:

- Fast, easy connecting/disconnecting of trailers with semi-automatic remote unlocking from the operator position (optional).
- Inching controls for simple coupling connect and disconnect (optional).
- Non-marking, solid pneumatic tires (optional).
- PIN (personal identification number) activation of the vehicle (optional).
- Supplementary chassis protection made from steel.
- Holder for RF data communications components.
- Different couplers.
- The built-in battery allows for convenient charging with no need to open panels.
- Cab with a variety of accessories for traveling outside warehouses.
- Built in compliance with ANSI/ITSDF B56.1 design specifications* for Type E industrial trucks with Type EO battery.

Parts when you need them

Jungheinrich's Parts Fast or Parts Free Guarantee ensures next-business day delivery of all Jungheinrich parts, or they're free, including freight. If your part doesn't come in by the next business day, we'll pay for it. See your local Jungheinrich dealer for program details.

* In accordance to specification in place at time of manufacture.

