

Broad capacity range for enhanced flexibility

High performance and high energy efficiency with advanced AC technology

Compact design for increased operation cycles

Ergonomic and easily adjustable operator compartment

Sealed components to help protect against dust and moisture



## EFG 540k – S50

**Electric Four-Wheel Counterbalanced Trucks (8,000 – 11,000 lbs.)**

### **The advantages of Jungheinrich® electrics**

Developed by the leader in AC lift truck technology, the newest generation of 3-phase AC technology offers a number of benefits:

- Maximum throughput with high acceleration, travel and lift speeds.
- Minimal energy consumption due to high efficiency and energy recovery.
- Minimal service costs due to the reduction of mechanical and hydraulic components.

The advantage: powerful drive and lift performance levels and the ability to run up to two shifts on a single battery charge in most applications. Combine this with reduced maintenance requirements, and you can significantly reduce the total cost of ownership for your business.

### **Hard working in tough conditions**

Harsh environments are no problem for the EFG 540k-S50 series of forklifts because major electrical components are sealed – motors are sealed to an Ingress Protection rating of IP54, and connectors are sealed to IP56. The enclosed cabin option provides a comfortable and productive environment for operators – even in wet, cold or extreme conditions.

# Technical data

				EFG540k		EFG 540		
Characteristics	1	Capacity at rated load center	lb	kg	8,000	4,000	8,000	4,000
	2	Rated load center	in	mm	24	500	24	500
	3	Power – diesel, gasoline, LP gas, electric			electric		electric	
	4	Tire type – cushion, pneumatic			pneumatic		pneumatic	
	5	Wheels, number front / rear (x=driven)			2x / 2		2x / 2	
Dimensions	6	Maximum fork height	in	mm	118	3,000	118	3,000
	7	Extended mast height	in	mm	166	4,220	166	4,220
	8	Fork free lift height (see tables)	in	mm	6	150	6	150
	9	Fork dimensions – length x width x thickness	in	mm	45 x 5 x 2	1150 x 125 x 50	45 x 5 x 2	1150 x 125 x 50
	10	Fork spacing – out-to-out minimum / maximum	in	mm	16.4 / 44.3	415 / 1,125	16.4 / 44.3	415 / 1,125
	11	Fork carriage type (to ISO 2328, class / type A,B)			3A		3A	
	12	Tilt forward / backward		deg	6° / 8°		6° / 8°	
	13	Overall length (incl. 45.25 in. forks)	in	mm	150.3	3,818	156.0	3,962
	14	Length to fork face (includes fork thickness)	in	mm	105.0	2,668	110.7	2,812
	15	Overall width	in	mm	52.8	1,340	52.8	1,340
	16	Lowered mast height	in	mm	88.6	2,250	88.6	2,250
	17	Ground to seat index point	in	mm	40.9	1,040	40.9	1,040
	18	Overhead guard height (top)	in	mm	93.1	2,365	93.1	2,365
	19	Tow coupling height	in	mm	15.6	396	15.6	396
20	Minimum outside turning radius	in	mm	89.9	2,284	96.5	2,450	
21	Load distance, axle to fork face (load moment constant)	in	mm	20.1	510	20.1	510	
22	Minimum aisle – 90° stack – zero clearance without load	in	mm	110.0	2,794	116.5	2,960	
Performance	23	Travel speed, loaded / unloaded (standard mode)	mph	km/h	8.7 / 10	14 / 16	8.7 / 10	14 / 16
	24	Travel speed, loaded / unloaded (high-performance option)	mph	km/h	9.3 / 10.6	15 / 17	9.3 / 10.6	15 / 17
	25	Lift speed, loaded / unloaded (standard mode)	fpm	m/s	61.0 / 84.6	0.31 / 0.43	61.0 / 84.6	0.31 / 0.43
	26	Lift speed, loaded / unloaded (high-performance option)	fpm	m/s	68.9 / 98.4	0.35 / 0.50	68.9 / 98.4	0.35 / 0.50
	27	Lowering speed, loaded / unloaded (standard mode)	fpm	m/s	106.3 / 90.6	0.54 / 0.46	106.3 / 90.6	0.54 / 0.46
	28	Lowering speed, loaded / unloaded (high-performance option)	fpm	m/s	108.3 / 98.4	0.55 / 0.50	108.3 / 98.4	0.55 / 0.50
	29	Gradeability, loaded at 1 mph (1.6 kmh) (standard mode)		%	9.3		9.3	
	30	Gradeability, loaded at 1 mph (1.6 kmh) (high-performance option)		%	10.8		10.8	
	31	Gradeability, maximum (unloaded) (standard mode)		%	22.3		22.3	
	32	Gradeability, maximum (unloaded) (high-performance option)		%	26.1		26.1	
Weight	33	Chassis with minimum weight battery (unloaded)	lb	kg	14,623	6,633	14,533	6,592
	34	Axle load with rated load, front / rear	lb	kg	21,265 / 2,177	9,646 / 987	21,224 / 2,128	9,627 / 965
	35	Axle load, unloaded, front / rear	lb	kg	7,725 / 6,899	3,504 / 3,129	8,037 / 6,495	3,646 / 2,946
Chassis	36	Tire size, front		in	250-15		250-15	
	37	Tire size, rear		in	21 x 8-9		21 x 8-9	
	38	Wheelbase	in	mm	73.1	1,856	78.7	2,000
	39	Track width, front / rear (center of tires)	in	mm	43.9 / 37.4	1,115 / 950	43.9 / 37.4	1,115 / 950
	40	Ground clearance at lowest point of mast	in	mm	5.4	136	5.4	136
	41	Ground clearance at center of wheelbase	in	mm	5.9	150	5.9	150
	42	Brakes – service		type	wet disc mechanical		wet disc mechanical	
	43	Brakes – parking		type	electric		electric	
Powertrain	44	Battery size (maximum)	in	mm	33.66x40.47x30.87	885x1,028x784	39.33x40.47x30.87	999x1,028x784
	45	Battery weight, minimum / maximum	lb	kg	3,902 / 4,436	1,770 / 2,012	4,562 / 5,186	2,069 / 2,352
	46	Drive motor capacity (60 min. rating) (standard mode)	HP	kW	19	14.5	19	14.5
	47	Drive motor capacity (60 min. rating) (high-performance option)	HP	kW	24	18	24	18
	48	Lift output (15% rating) (standard mode)	HP	kW	27	20	27	20
	49	Lift output (15% rating) (high-performance mode)	HP	kW	32	24	32	24
	50	Truck voltage		Volt	80		80	
	51	Controls – drive / hydraulic		type	AC / AC		AC / AC	
	52	Hydraulic pressure for attachments	PSI	Mpa	2,900	20	2,900	20
	53	Hydraulic flow rate for attachments	gpm	lpm	7.9	30	7.9	30

This specification sheet only provides technical values for the standard truck. Non-standard tires, different masts, different axle widths, additional equipment, etc. could produce other values. Rights reserved for technical changes and improvements.

EFG S40		EFG 545k		EFG 545		EFG 550		EFG S50	
8,500	4,000	9,000	4,500	9,000	4,500	10,000	5,000	11,000	5,000
24	600	24	500	24	500	24	500	24	600
electric		electric		electric		electric		electric	
pneumatic		pneumatic		pneumatic		pneumatic		pneumatic	
2x / 2		2x / 2		2x / 2		2x / 2		2x / 2	
118	3,000	118	3,000	118	3,000	118	3,000	118	3,000
166	4,220	166	4,220	166	4,220	166	4,220	166	4,220
6	150	6	150	6	150	6	150	6	150
45 x 6 x 2	1150 x 150 x 50	45 x 6 x 2	1150 x 150 x 50	45 x 6 x 2	1150 x 150 x 50	45 x 6 x 2	1150 x 150 x 50	45 x 6 x 2.4	1150 x 150 x 60
16.5 / 44.5	420 / 1,130	16.5 / 44.5	420 / 1,130	16.5 / 44.5	420 / 1,130	16.5 / 44.5	420 / 1,130	16.5 / 44.5	420 / 1,130
3A		3A		3A		3A		4A	
6° / 8°		6° / 8°		6° / 8°		6° / 8°		6° / 8°	
161.5	4,102	150.3	3,818	144.1	3,660	156.0	3,962	161.5	4,102
115.0	2,922	105.0	2,668	110.7	2,812	110.7	2,812	116.2	2,952
57.1	1,450	57.1	1,450	57.1	1,450	57.1	1,450	57.1	1,450
88.0	2,236	88.0	2,236	88.0	2,236	88.0	2,236	88.0	2,236
40.9	1,040	40.9	1,040	40.9	1,040	40.9	1,040	40.9	1,040
92.5	2,350	92.5	2,350	92.5	2,350	92.5	2,350	92.5	2,350
15.6	396	15.6	396	15.6	396	15.6	396	15.6	396
103.8	2,637	89.9	2,284	96.5	2,450	96.5	2,450	103.8	2,637
20.1	510	20.1	510	20.1	510	20.1	510	20.1	510
123.9	3,147	110.0	2,794	116.5	2,960	116.5	2,960	123.9	3,147
8.7 / 9.6	14 / 15.5	8.7 / 9.6	14 / 15.5	8.7 / 9.6	14 / 15.5	8.7 / 9.3	14 / 15	8.4 / 9	13.5 / 14.5
9.3 / 10.3	15 / 16.5	9.3 / 10.3	15 / 16.5	9.3 / 10.3	15 / 16.5	9.3 / 10	15 / 16	9 / 9.6	14.5 / 15.5
59.1 / 80.7	0.30 / 0.41	59.1 / 80.7	0.30 / 0.41	59.1 / 80.7	0.30 / 0.41	55.1 / 80.7	0.28 / 0.41	53.1 / 78.7	0.27 / 0.40
65.0 / 88.6	0.33 / 0.45	65.0 / 88.6	0.33 / 0.45	65.0 / 88.6	0.33 / 0.45	65.0 / 88.6	0.33 / 0.45	61.0 / 88.6	0.31 / 0.45
102.4 / 92.5	0.52 / 0.47	102.4 / 92.5	0.52 / 0.47	102.4 / 92.5	0.52 / 0.47	102.4 / 92.5	0.52 / 0.47	100.4 / 98.4	0.51 / 0.50
108.3 / 98.4	0.55 / 0.50	108.3 / 98.4	0.55 / 0.50	108.3 / 98.4	0.55 / 0.50	18.3 / 98.4	0.55 / 0.50	108.3 / 98.4	0.55 / 0.50
8.1		8.1		8.1		7.5		7.1	
9.4		9.4		9.4		8.8		8.4	
20.4		20.4		20.4		20		18.9	
23.4		23.9		23.9		23.4		22.2	
15,580	7,067	15,637	7,093	15,547	7,052	16,402	7,440	17,476	7,927
21,886 / 2,522	9,927 / 1,144	23,200 / 2,358	10,524 / 1,069	23,039 / 2,429	10,450 / 1,102	24,656 / 2,747	11,184 / 1,246	25,528 / 2,971	11,579 / 1,348
8,448 / 7,132	3,832 / 3,235	7,962 / 7,675	3,612 / 3,481	8,200 / 7,349	3,702 / 3,333	8,196 / 8,207	3,718 / 3,722	8,551 / 8,925	3,879 / 4,048
28 x 12.5-15		28 x 12.5-15		28 x 12.5-15		28 x 12.5-15		28 x 12.5-15	
23 x 10-12		21 x 8-9		21 x 8-9		21 x 8-9		23 x 10-12	
81.9	2,080	73.1	1,856	78.7	2,000	78.7	2,000	81.9	2,080
43.9 / 47.2	1,115 / 1,200	43.9 / 37.4	1,115 / 950	43.9 / 37.4	1,115 / 950	43.9 / 37.4	1,115 / 950	43.9 / 47.2	1,115 / 1,200
4.8	122	4.8	122	4.8	122	4.8	122	4.8	122
5.9	150	5.9	150	5.9	150	5.9	150	5.9	150
wet disc mechanical		wet disc mechanical		wet disc mechanical		wet disc mechanical		wet disc mechanical	
electric		electric		electric		electric		electric	
39.33x40.47x30.87	999x1,028x784	33.66x40.47x30.87	855x1,028x784	39.33x40.47x30.87	999x1,028x784	39.33x40.47x30.87	999x1,028x784	39.33x40.47x30.87	999x1,028x784
4,562 / 5,186	2,069 / 2,352	3,902 / 4,436	1,770 / 2,012	4,562 / 5,186	2,069 / 2,352	4,562 / 5,186	2,069 / 2,352	4,562 / 5,186	2,089 / 2,352
19	14	19	14.5	19	14	19	14	19	14
24	18	24	18	24	18	24	18	24	18
27	20	27	20	27	20	27	20	27	20
32	24	32	24	32	24	32	24	32	24
80		80		80		80		80	
AC / AC		AC / AC		AC / AC		AC / AC		AC / AC	
2,900	20	2,900	20	2,900	20	2,900	20	2,900	20
7.9	30	7.9	30	7.9	30	7.9	30	7.9	30



# EFG 540k-S50

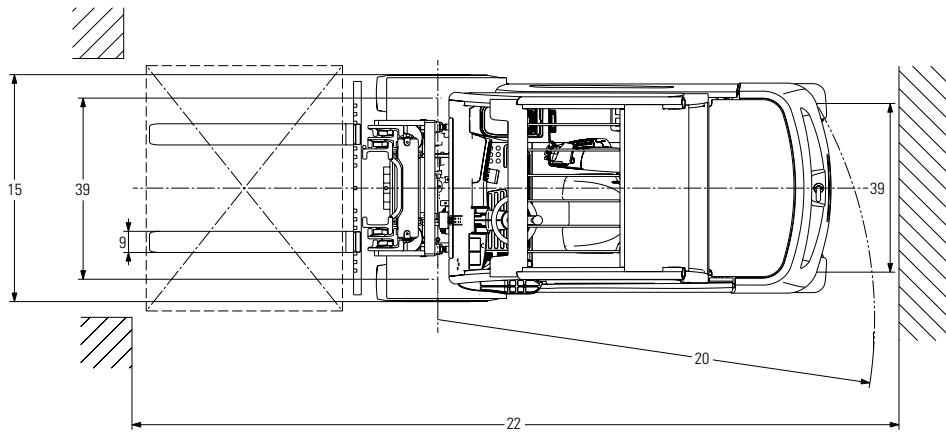
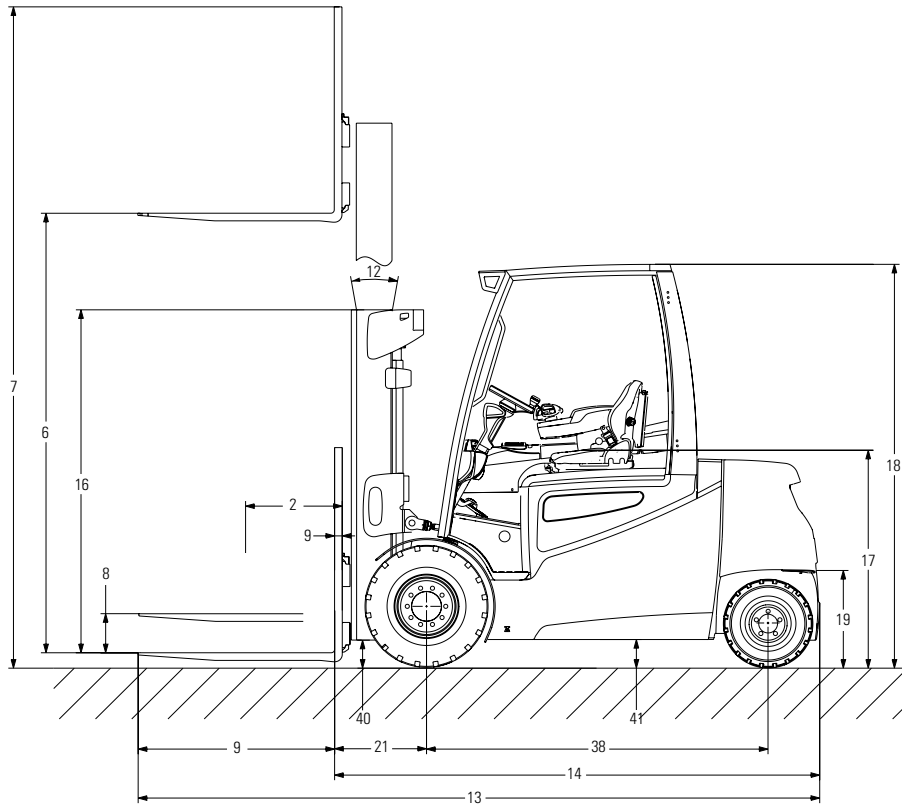

# The Jungheinrich Advantage



Ergonomic operator compartment

## Superior operator comfort

The ergonomic operator compartment allows for relaxed and productive operation, beneficial during long shifts:

- Low, wide step with slip-resistant tread.
- Ability to telescope and tilt the narrow steering column to suit the operator's needs.
- All essential controls are located on the highly-adjustable armrest with the SOLO-PILOT fingertip hydraulic control feature, allowing for easy, intuitive operator control.
- Operators will experience an extremely comfortable ride on rough or uneven floors with the combination of solid pneumatic tires, a three-way adjustable seat and floating cabin.
- Outstanding view thanks to an innovative overhead guard design, optimized mast channel nesting and hose routing.

## Maintenance-free braking system

- Regenerative braking with the traction motor allows for smooth, energy efficient deceleration and puts energy back into the battery.
- Automatically engaging parking brake for secure stopping.
- Multiple wet disc brakes are sealed for extreme durability in harsh environments.



A smooth ride even in outdoor applications

## Maintenance-free motors

The new generation of 3-phase AC motors will impress – providing quiet and precise operation at all speeds.

- High torque for faster operation cycles.
- Lifetime lubrication of main components.
- Motor, brake and gears are integrated into the sealed drive axle.
- Dust and water protection to IP54.

## Control systems

High performance also requires a high degree of control. That's why the EFG series includes a comprehensive range of equipment for more secure operation:

- Compact electronic and hydraulic design makes for minimal power usage – longer power cycles with less energy consumed.
- Deactivation of all hydraulic and travel functions when the operator seat is not occupied.
- Limited roll-back on ramps or inclines with the automatic parking brake.
- Automatic progressive reduction of the driving speed during cornering with Jungheinrich Curve Control.
- Side battery extraction for easier maintenance.



Optimized visibility

## Intelligent electronics

- Smooth travel / reversing and precise positioning.
- Optimally adapts to any situation using five individual work programs.
- Efficient communication between the truck and operator / technician with the highly informative, interactive display.

## Available options

- Optional electro-hydraulic steering.
- MULTI-PILOT unitized hydraulic control
- Cold storage / tropics conditioning
- Dual solid pneumatic or non-marking tires
- Hydraulic accumulator shock absorber
- Fully enclosed cabin
- Deluxe cloth 3-way adjustable air suspension seat
- 15° swivel seat
- Rear grab handle with horn button
- DC / DC converter
- Light and warning options

## Parts when you need them

Jungheinrich's Parts Fast or Parts Free Guarantee ensures next-business-day delivery by 5:00 p.m. of all Jungheinrich parts in the United States, or they're free, including freight. For customers in Canada and Mexico, the guarantee ensures shipping of parts within 24 hours from the time the order was placed by the dealer. See your local Jungheinrich dealer for program details.

\* Programs may be subject to change without notice and may vary by region. Please ask your local Jungheinrich dealer for complete terms and conditions.